

Combining the CLC and NCO to Implement a High-Resolution PWM

Author: Cobus Van Eeden
Microchip Technology Inc.

INTRODUCTION

Although many applications can function with PWM resolutions of less than eight bits, there is a range of applications, such as dimming of lamps, where higher resolution is required due to the sensitivity of the human eye.

BACKGROUND

A conventional PWM uses a timer to produce a regular switching frequency (T_{PWM}), and then uses a ripple counter to determine how many clocks the output is held high before the pulse ends.

The output pulse width is adjusted as indicated in [Figure 1](#) to produce, in this case, a PWM with five possible duty cycle settings (0%, 25%, 50%, 75% or 100%).

FIGURE 1: CONVENTIONAL PWM

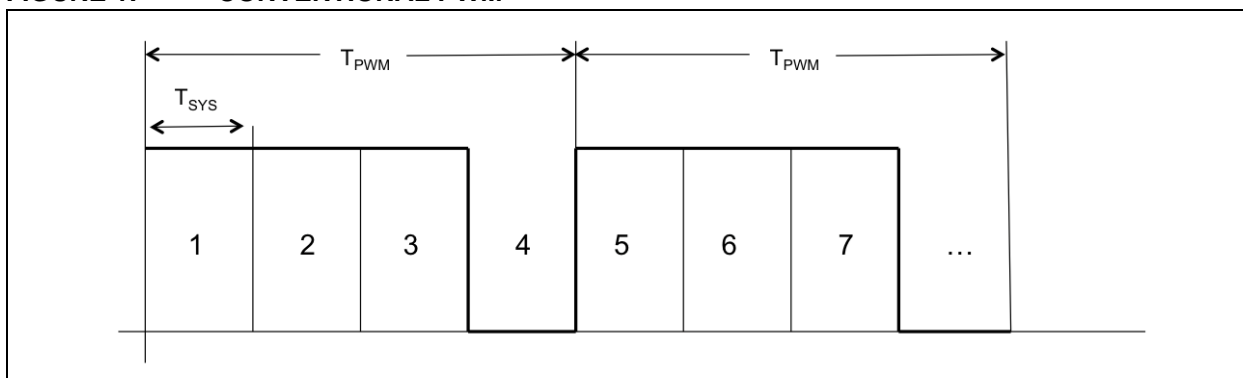

The effective resolution (measured in bits) of a PWM can be calculated by taking the base-2 logarithm of the number of pulse width settings (N) possible.

EQUATION 1: PWM RESOLUTION

$$Resolution = \log_2(N)$$

For a device running at 16 MHz, the smallest duty cycle adjustment increment would be 62.5 ns (one system clock). If the PWM is configured to run at a switching frequency of 200 kHz (switching period of 5 μ s), 100% duty cycle will be achieved when the duty cycle register is set to 80 clocks (80 x 62.5 ns = 5 μ s). This would make the effective PWM resolution only slightly more than six bits, as there are 80 steps to choose from. This is because one system clock divides into one period 80 times.

Knowing that there are 80 possible duty cycle steps, a precise value for the resolution of the PWM can be calculated as follows ([Equation 2](#)):

EQUATION 2: PWM RESOLUTION EXAMPLE

$$\log_2 80 = 6.32 \text{ bits}$$

A PWM running from a 16 MHz clock, which has a 10-bit duty cycle register, will start losing resolution due to this limitation at a 15.6 kHz switching frequency. For higher PWM switching frequencies, the duty cycle will reach 100% before all of the steps in the 10-bit duty cycle register have been used, and for all the remaining values the output will simply remain at 100% duty cycle.

The frequency at which this point is reached can be calculated as follows ([Equation 3](#)):

EQUATION 3: SWITCHING FREQUENCY LIMITATION

$$\frac{F_{osc}}{\#Steps} = \frac{16MHz}{2^{10}} = \frac{16,000,000}{1024} = 15.6 \text{ kHz}$$

In most PWM applications, the PWM is switched at a much higher frequency than the output can ever change. By filtering this PWM signal using a low-pass filter, the desired output is obtained. The filter removes the high-frequency switching components of the PWM by essentially calculating the average value of the PWM signal, and presents this as the output. For example, in a switching power supply, the output voltage will be directly proportional to the duty cycle. The consequence of this relationship is that the smaller the adjustment to the PWM duty cycle, the smaller the resulting change to the output will be resulting in more precise control of the output.

From a control systems point of view, being able to make small adjustments to the output effectively lowers the quantization gain introduced by the PWM. In control systems, this lowering of the gain is important to ensure stability of the system.

DESIGN

PWM Construction

In principal, a PWM is created by the combination of the two parameters. The first being a repeating trigger, which determines how often the switching period or switching frequency are pulsed, and the second being a single-pulse generator, which determines how wide the pulse is (the duty cycle). This is illustrated in [Figure 2](#).

FIGURE 2: PWM CONSTRUCTION

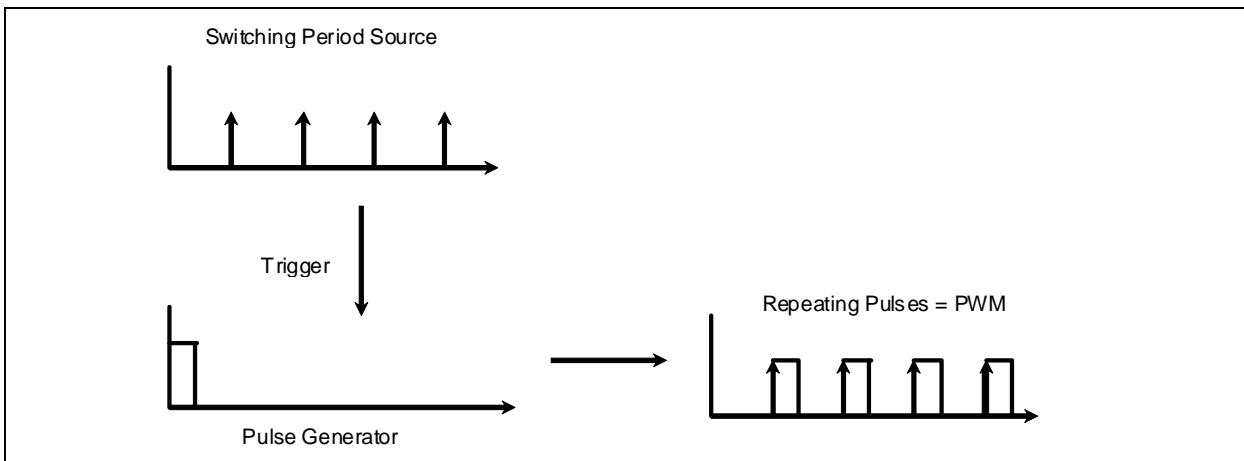

In order to achieve an increase in the effective PWM resolution, the NCO peripheral on the PIC[®] device will be used to create a monostable circuit (a circuit that gives a single pulse of fixed duration when triggered).

The NCO will generate a signal that varies between two values in a defined proportion, creating an average pulse width, which is somewhere in between two system clocks, as illustrated in [Figure 3](#). The PWM signal pulse width will vary (jitter/dither) by one clock period, with the proportion/ratio of the variation precisely determined by the NCO configuration.

FIGURE 3: NCO BASED PWM OPERATION

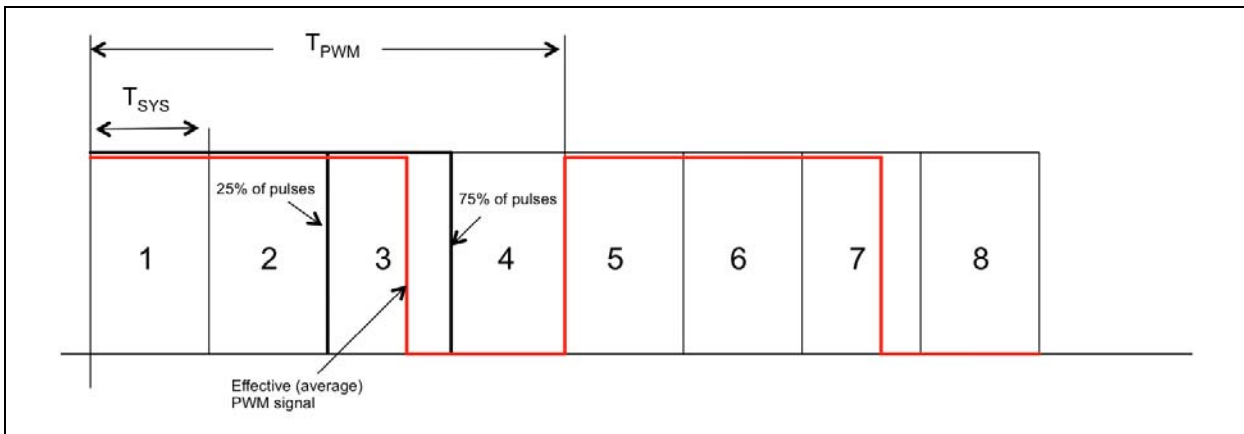

In any application where the output is producing an average value (e.g., average power transfer to the load in SMPS or lighting applications), the variation in pulse width will be perfectly acceptable, because the average pulse width is accurately controlled.

By itself, the NCO peripheral cannot produce a PWM signal, but its behavior can be changed by adding some logic using the CLC to produce a PWM output.

This can be achieved by using the conventional PWM as a clock source to trigger the PWM period, and use the NCO to determine the pulse width. Any number of clock sources could be used (e.g., Timers or even external signals), and in some applications an external trigger can be used to start the pulses, such as a zero-current detection circuit for power supplies. A simplified block diagram of how this will work is shown in Figure 4.

FIGURE 4: NCO-BASED PWM PRINCIPLE OF OPERATION

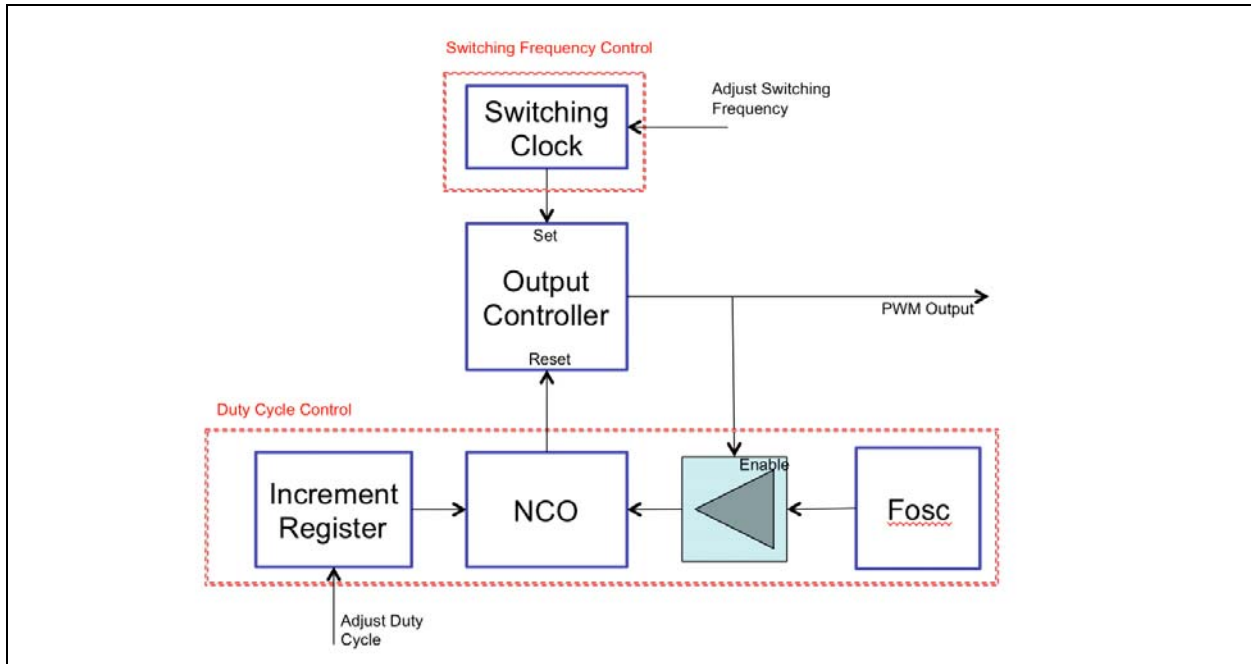

The control logic in the CLC is used to set an output when the switching clock indicates that it is time for the next pulse, and clear this output to complete the pulse once the NCO overflows.

IMPLEMENTATION USING CLC AND NCO

An implementation of this design using the NCO and CLC is shown in [Figure 5](#). For this design, the NCO is placed in Pulse Frequency mode. In this mode of operation, a short pulse is produced when the NCO overflows.

The operation of the circuit can be described as follows:

1. When the system begins, the NCO output is low because it is waiting for enough clocks to count until it overflows and produces a pulse. This low output signal is inverted so that the PWM output becomes high and is fed into U2. This will supply a high-speed clock back into the NCO clock pin via U3.
2. The PWM output will remain high until the accumulator overflows and the NCO output changes. This will cause U2 to stop producing the clock needed to run the NCO. At this point, the NCO is stuck high until it can get the clocks

needed to finish its pulse. The PWM output is now low.

3. The timing source will then pulse high through U1 when the next period begins, feeding the high-speed clock back to the NCO via U3.
4. The NCO uses these few clocks to finish the pulse, and then the output toggles back to the low position where it starts the process over from step 1 above. The amount of time it takes the NCO to overflow will depend on the remainder left in the accumulator after the last overflow, as well as the increment register. Due to the accumulation of remainders the pulse will sometimes be one system clock shorter than usual. By controlling how often this happens (setting the increment register), the exact average pulse width can be controlled.

FIGURE 5: PWM IMPLEMENTATION USING CLC AND NCO

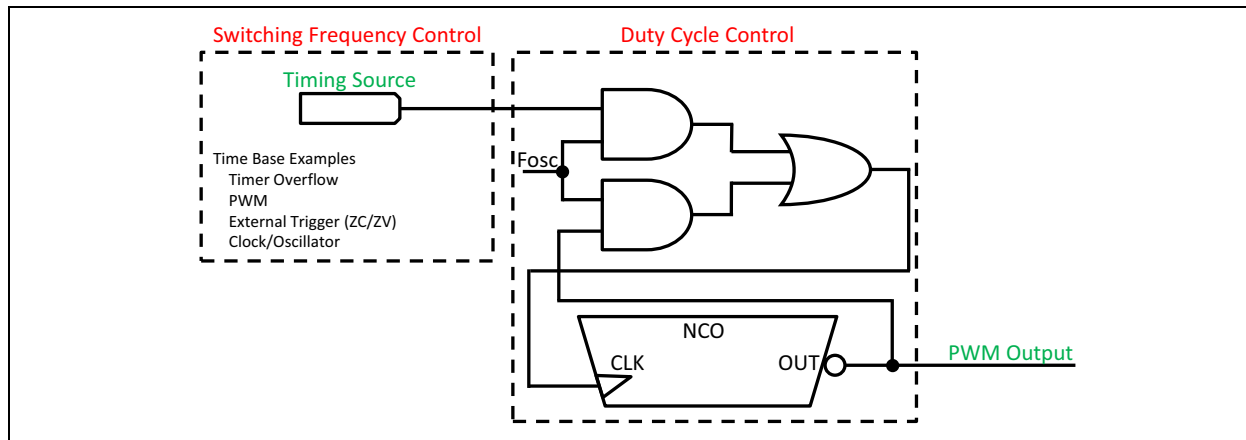

CALCULATIONS

The calculation of the pulse width will be according to the NCO overflow frequency calculation, as listed in the data sheet.

EQUATION 4: OUTPUT FREQUENCY

$$F_{OUT} = F_{NCO} \times \frac{Increment}{2^n}$$

The average overflow frequency of the NCO will determine the average output pulse width (T_{PULSE}) produced.

EQUATION 5: AVERAGE PULSE WIDTH

$$T_{PULSE} = \frac{1}{F_{OUT}}$$

[Table 1](#) below shows the pulse width, which this circuit will produce using a 16 MHz clock connected directly to the NCO clock input (F_{NCO}), given various increment register values. Note that, for high increment values, a single increment of the register will change the pulse width by a mere 15 ps.

TABLE 1: CALCULATED PWM PULSE WIDTH FOR DIFFERENT INCREMENT REGISTER VALUES

Increment Value	NCO Fout (Hz)	Average Pulse Width (ns)
65000	991,821	1,008.246
65001	991,837	1,008.231
20000	305,176	3,276.800
20001	305,191	3,276.636
100	1,526	655,360.000
101	1,541	648,871.287

CHARACTERISTICS

It is important to note that the NCO is designed to give linear control over frequency. The control over pulse width is subsequently not linear. As can be seen from the equation for calculating T_{PULSE} above (Equation 5), the pulse width will vary with the inverse of the frequency ($1/x$).

The result is that the effective resolution of the PWM is not constant over the entire range from 0% to 100% duty cycle.

For every duty cycle setting, the effective resolution at this particular point can be calculated and then plotted on a graph. This curve will look different depending on what the switching frequency is, the pulse width being adjusted independently from the switching frequency. For a $F_{sw} = 3$ kHz and a 16 MHz clock, the graphic will look as follows (Figure 6).

FIGURE 6: HIGH RES PWM RESOLUTION PLOTTED AGAINST DUTY CYCLE (CLOCK = 16 MHz, Fsw = 3 kHz)

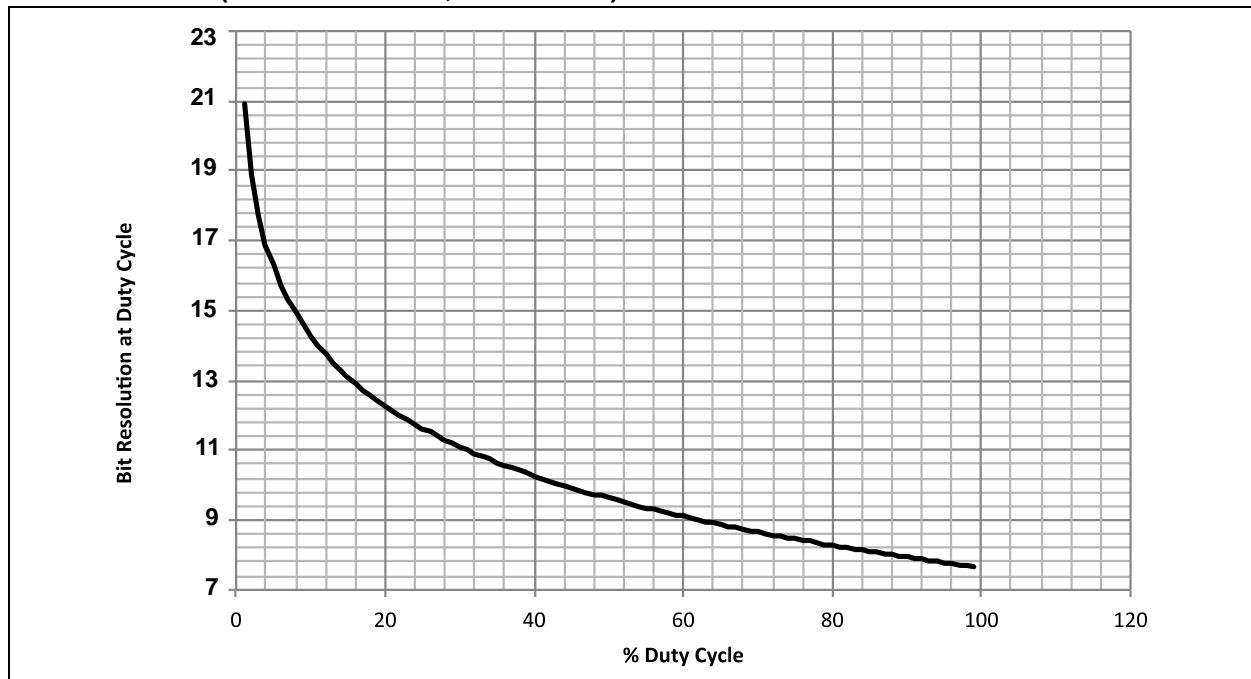

Although there is an equivalent of 21 bits of resolution close to 0% duty cycle, this deteriorates to only 7.5 bits of resolution at 100% duty cycle, at which point the conventional PWM would outperform our high-resolution implementation.

Interestingly, and perhaps counter-intuitively, the resolution can be improved by decreasing the NCO input clock frequency. Reducing this clock to 1 MHz will have the result shown below (Figure 7).

FIGURE 7: HIGH RES PWM RESOLUTION PLOTTED AGAINST DUTY CYCLE (CLOCK = 1 MHz, Fsw = 3 kHz)

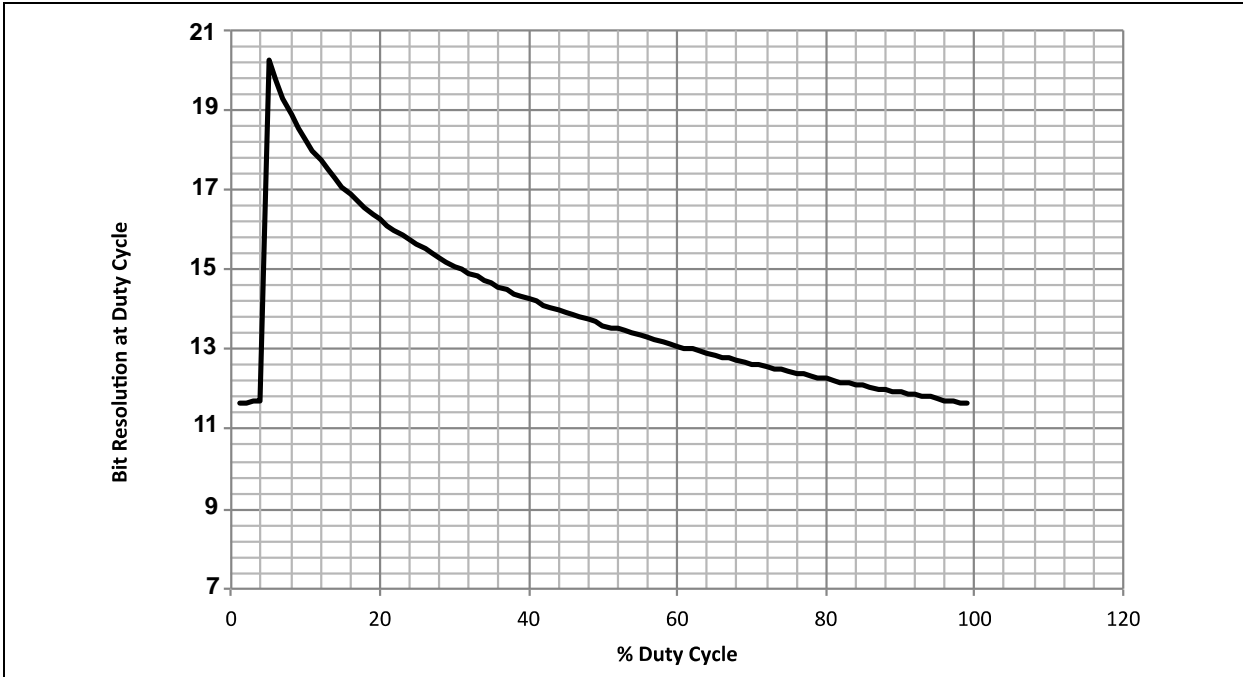

There is, of course, a limitation, as can be seen, close to 0% duty cycle, where the increment register maximum value is reached and smaller pulses cannot be generated any more, but the resolution now never reduces to less than 11 bits.

One way to improve the performance would be to invert the PWM signal when it exceeds 50% duty cycle. Doing this can effectively mirror the performance under 50% duty cycle to the region above it, with the higher resolution. There is still the option to use the original curve where the limits of the increment are reached. This results in the following graphic (Figure 8) for the same conditions as the graphic above.

FIGURE 8: RESOLUTION VS DUTY CYCLE WITH SIGNAL INVERSION AT 50% DUTY CYCLE (CLOCK = 1 MHz, Fsw = 3 kHz)

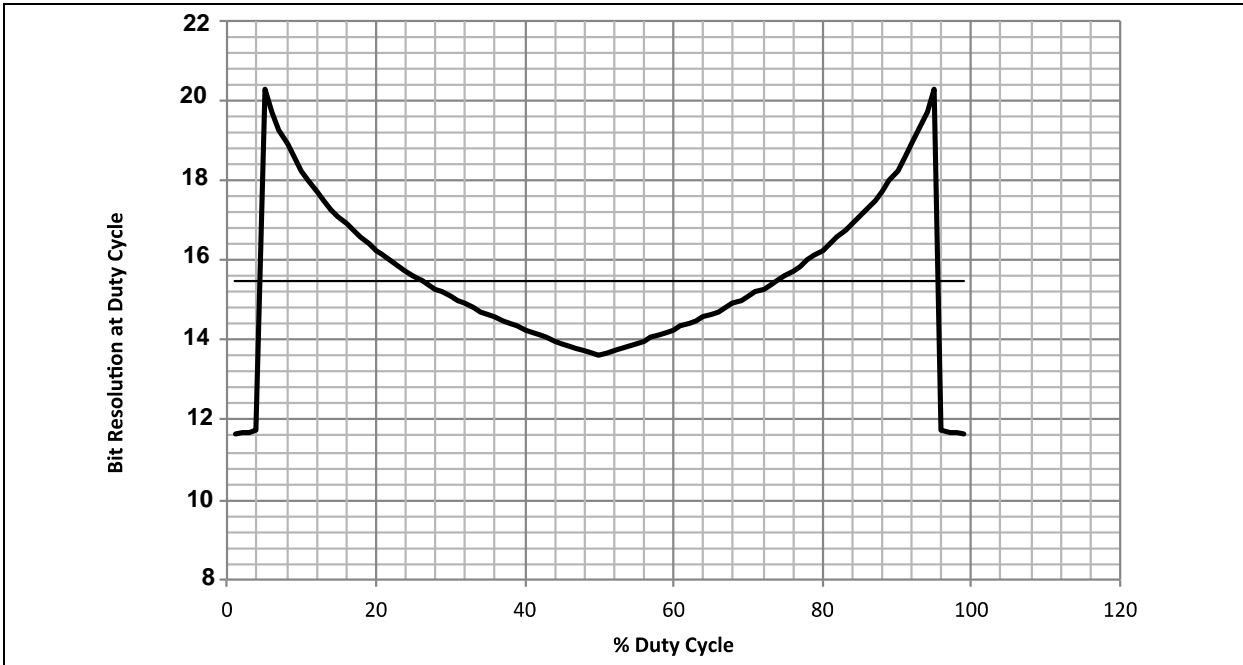

When the intention is to achieve both the highest possible switching frequency and the highest resolution using this technique, the configuration shown below can be used (Figure 9). This graphic shows the achievable resolution when using a 16 MHz clock at a switching frequency of 500 kHz.

FIGURE 9: HIGH RES PWM RESOLUTION PLOTTED AGAINST DUTY CYCLE WITH INVERSION AT 50% (CLOCK = 16 MHz, F_{sw} = 500 kHz)

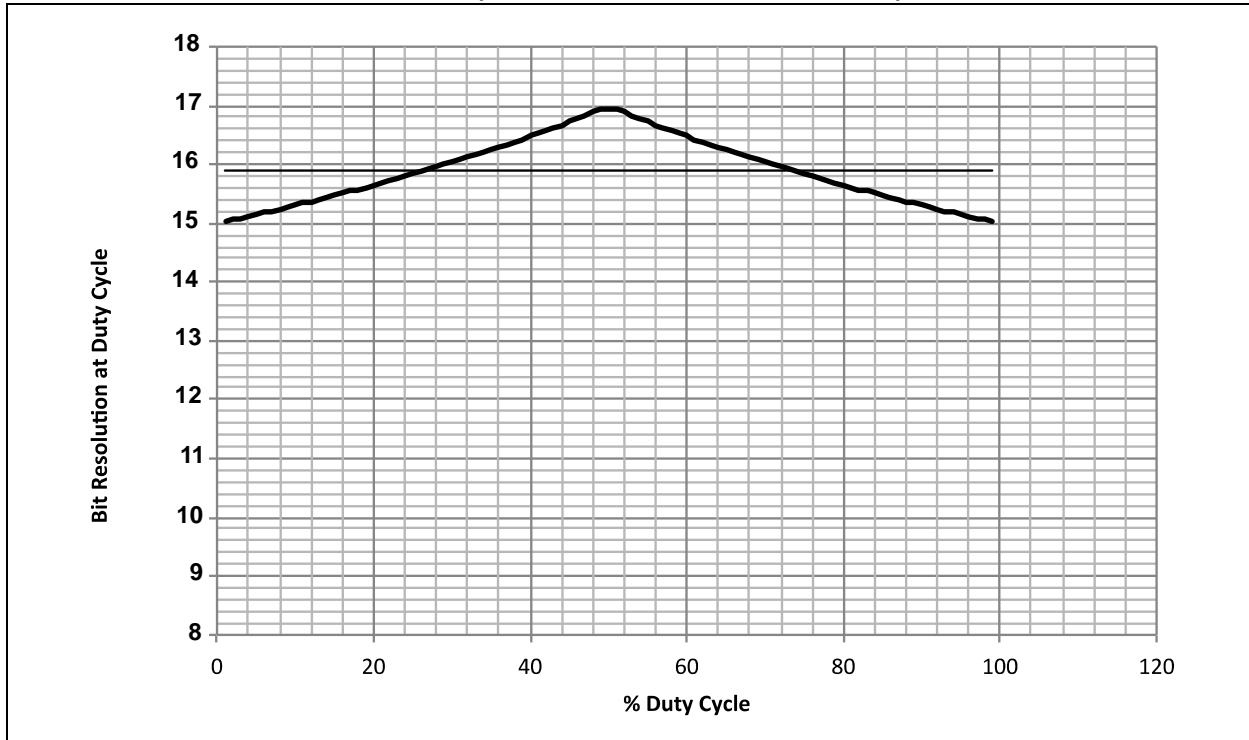

SUMMARY

Conventional PWMs start losing effective resolution at relatively low-switching frequencies. For applications where the switching frequencies have to be fairly high, and having as much PWM resolution as possible at these frequencies is necessary, the NCO can be used in conjunction with the CLC to create a very high-resolution PWM output.

The smallest incremental change in pulse width achievable by a conventional PWM with a 16 MHz system clock speed would be 62.5 ns. If the fastest available PWM clock is $F_{osc}/4$, then this increases to 250 ns.

On the same device, a PWM with an incremental pulse width change of as little as 15 ps can be constructed using the technique described in this application note.

Even if the requirement is not primarily high resolution, this solution may still be attractive for a number of applications, adding an additional PWM to the capability of the device, or having a constant on/off-time variable frequency PWM, where the pulse is triggered externally as required, when doing zero current switching in high-efficiency power converters.

Note the following details of the code protection feature on Microchip devices:

- Microchip products meet the specification contained in their particular Microchip Data Sheet.
- Microchip believes that its family of products is one of the most secure families of its kind on the market today, when used in the intended manner and under normal conditions.
- There are dishonest and possibly illegal methods used to breach the code protection feature. All of these methods, to our knowledge, require using the Microchip products in a manner outside the operating specifications contained in Microchip's Data Sheets. Most likely, the person doing so is engaged in theft of intellectual property.
- Microchip is willing to work with the customer who is concerned about the integrity of their code.
- Neither Microchip nor any other semiconductor manufacturer can guarantee the security of their code. Code protection does not mean that we are guaranteeing the product as “unbreakable.”

Code protection is constantly evolving. We at Microchip are committed to continuously improving the code protection features of our products. Attempts to break Microchip's code protection feature may be a violation of the Digital Millennium Copyright Act. If such acts allow unauthorized access to your software or other copyrighted work, you may have a right to sue for relief under that Act.

Information contained in this publication regarding device applications and the like is provided only for your convenience and may be superseded by updates. It is your responsibility to ensure that your application meets with your specifications. MICROCHIP MAKES NO REPRESENTATIONS OR WARRANTIES OF ANY KIND WHETHER EXPRESS OR IMPLIED, WRITTEN OR ORAL, STATUTORY OR OTHERWISE, RELATED TO THE INFORMATION, INCLUDING BUT NOT LIMITED TO ITS CONDITION, QUALITY, PERFORMANCE, MERCHANTABILITY OR FITNESS FOR PURPOSE. Microchip disclaims all liability arising from this information and its use. Use of Microchip devices in life support and/or safety applications is entirely at the buyer's risk, and the buyer agrees to defend, indemnify and hold harmless Microchip from any and all damages, claims, suits, or expenses resulting from such use. No licenses are conveyed, implicitly or otherwise, under any Microchip intellectual property rights unless otherwise stated.

Trademarks

The Microchip name and logo, the Microchip logo, dsPIC, FlashFlex, flexPWR, JukeBlox, KEELOQ, KEELOQ logo, Klear, LANCheck, MediaLB, MOST, MOST logo, MPLAB, OptoLyzer, PIC, PICSTART, PIC³² logo, RightTouch, SpyNIC, SST, SST Logo, SuperFlash and UNI/O are registered trademarks of Microchip Technology Incorporated in the U.S.A. and other countries.

The Embedded Control Solutions Company and mTouch are registered trademarks of Microchip Technology Incorporated in the U.S.A.

Analog-for-the-Digital Age, BodyCom, chipKIT, chipKIT logo, CodeGuard, dsPICDEM, dsPICDEM.net, ECAN, In-Circuit Serial Programming, ICSP, Inter-Chip Connectivity, KlearNet, KlearNet logo, MiWi, MPASM, MPF, MPLAB Certified logo, MPLIB, MPLINK, MultiTRAK, NetDetach, Omniscient Code Generation, PICDEM, PICDEM.net, PICkit, PICtail, RightTouch logo, REAL ICE, SQI, Serial Quad I/O, Total Endurance, TSHARC, USBCheck, VariSense, ViewSpan, WiperLock, Wireless DNA, and ZENA are trademarks of Microchip Technology Incorporated in the U.S.A. and other countries.

SQTP is a service mark of Microchip Technology Incorporated in the U.S.A.

Silicon Storage Technology is a registered trademark of Microchip Technology Inc. in other countries.

GestIC is a registered trademark of Microchip Technology Germany II GmbH & Co. KG, a subsidiary of Microchip Technology Inc., in other countries.

All other trademarks mentioned herein are property of their respective companies.

© 2012-2015, Microchip Technology Incorporated, Printed in the U.S.A., All Rights Reserved.

ISBN: 978-1-63277-695-2

QUALITY MANAGEMENT SYSTEM
CERTIFIED BY DNV
== ISO/TS 16949 ==

Microchip received ISO/TS-16949:2009 certification for its worldwide headquarters, design and wafer fabrication facilities in Chandler and Tempe, Arizona; Gresham, Oregon and design centers in California and India. The Company's quality system processes and procedures are for its PIC[®] MCUs and dsPIC[®] DSCs, KEELOQ[®] code hopping devices, Serial EEPROMs, microperipherals, nonvolatile memory and analog products. In addition, Microchip's quality system for the design and manufacture of development systems is ISO 9001:2000 certified.



MICROCHIP

Worldwide Sales and Service

AMERICAS

Corporate Office

2355 West Chandler Blvd.
Chandler, AZ 85224-6199

Tel: 480-792-7200

Fax: 480-792-7277

Technical Support:

[http://www.microchip.com/
support](http://www.microchip.com/support)

Web Address:

www.microchip.com

Atlanta

Duluth, GA

Tel: 678-957-9614

Fax: 678-957-1455

Austin, TX

Tel: 512-257-3370

Boston

Westborough, MA

Tel: 774-760-0087

Fax: 774-760-0088

Chicago

Itasca, IL

Tel: 630-285-0071

Fax: 630-285-0075

Cleveland

Independence, OH

Tel: 216-447-0464

Fax: 216-447-0643

Dallas

Addison, TX

Tel: 972-818-7423

Fax: 972-818-2924

Detroit

Novi, MI

Tel: 248-848-4000

Houston, TX

Tel: 281-894-5983

Indianapolis

Noblesville, IN

Tel: 317-773-8323

Fax: 317-773-5453

Los Angeles

Mission Viejo, CA

Tel: 949-462-9523

Fax: 949-462-9608

New York, NY

Tel: 631-435-6000

San Jose, CA

Tel: 408-735-9110

Canada - Toronto

Tel: 905-673-0699

Fax: 905-673-6509

ASIA/PACIFIC

Asia Pacific Office

Suites 3707-14, 37th Floor
Tower 6, The Gateway
Harbour City, Kowloon

Hong Kong

Tel: 852-2943-5100

Fax: 852-2401-3431

Australia - Sydney

Tel: 61-2-9868-6733

Fax: 61-2-9868-6755

China - Beijing

Tel: 86-10-8569-7000

Fax: 86-10-8528-2104

China - Chengdu

Tel: 86-28-8665-5511

Fax: 86-28-8665-7889

China - Chongqing

Tel: 86-23-8980-9588

Fax: 86-23-8980-9500

China - Dongguan

Tel: 86-769-8702-9880

China - Hangzhou

Tel: 86-571-8792-8115

Fax: 86-571-8792-8116

China - Hong Kong SAR

Tel: 852-2943-5100

Fax: 852-2401-3431

China - Nanjing

Tel: 86-25-8473-2460

Fax: 86-25-8473-2470

China - Qingdao

Tel: 86-532-8502-7355

Fax: 86-532-8502-7205

China - Shanghai

Tel: 86-21-5407-5533

Fax: 86-21-5407-5066

China - Shenyang

Tel: 86-24-2334-2829

Fax: 86-24-2334-2393

China - Shenzhen

Tel: 86-755-8864-2200

Fax: 86-755-8203-1760

China - Wuhan

Tel: 86-27-5980-5300

Fax: 86-27-5980-5118

China - Xian

Tel: 86-29-8833-7252

Fax: 86-29-8833-7256

ASIA/PACIFIC

China - Xiamen

Tel: 86-592-2388138

Fax: 86-592-2388130

China - Zhuhai

Tel: 86-756-3210040

Fax: 86-756-3210049

India - Bangalore

Tel: 91-80-3090-4444

Fax: 91-80-3090-4123

India - New Delhi

Tel: 91-11-4160-8631

Fax: 91-11-4160-8632

India - Pune

Tel: 91-20-3019-1500

Japan - Osaka

Tel: 81-6-6152-7160

Fax: 81-6-6152-9310

Japan - Tokyo

Tel: 81-3-6880-3770

Fax: 81-3-6880-3771

Korea - Daegu

Tel: 82-53-744-4301

Fax: 82-53-744-4302

Korea - Seoul

Tel: 82-2-554-7200

Fax: 82-2-558-5932 or

82-2-558-5934

Malaysia - Kuala Lumpur

Tel: 60-3-6201-9857

Fax: 60-3-6201-9859

Malaysia - Penang

Tel: 60-4-227-8870

Fax: 60-4-227-4068

Philippines - Manila

Tel: 63-2-634-9065

Fax: 63-2-634-9069

Singapore

Tel: 65-6334-8870

Fax: 65-6334-8850

Taiwan - Hsin Chu

Tel: 886-3-5778-366

Fax: 886-3-5770-955

Taiwan - Kaohsiung

Tel: 886-7-213-7828

Taiwan - Taipei

Tel: 886-2-2508-8600

Fax: 886-2-2508-0102

Thailand - Bangkok

Tel: 66-2-694-1351

Fax: 66-2-694-1350

EUROPE

Austria - Wels

Tel: 43-7242-2244-39

Fax: 43-7242-2244-393

Denmark - Copenhagen

Tel: 45-4450-2828

Fax: 45-4485-2829

France - Paris

Tel: 33-1-69-53-63-20

Fax: 33-1-69-30-90-79

Germany - Dusseldorf

Tel: 49-2129-3766400

Germany - Munich

Tel: 49-89-627-144-0

Fax: 49-89-627-144-44

Germany - Pforzheim

Tel: 49-7231-424750

Italy - Milan

Tel: 39-0331-742611

Fax: 39-0331-466781

Italy - Venice

Tel: 39-049-7625286

Netherlands - Drunen

Tel: 31-416-690399

Fax: 31-416-690340

Poland - Warsaw

Tel: 48-22-3325737

Spain - Madrid

Tel: 34-91-708-08-90

Fax: 34-91-708-08-91

Sweden - Stockholm

Tel: 46-8-5090-4654

UK - Wokingham

Tel: 44-118-921-5800

Fax: 44-118-921-5820

01/27/15